

APPLICATION NOTE

Test for Saturation Magnetization

Introduction

The room temperature saturation magnetization ($4\pi Ms$) of a ferrimagnet is an intrinsic characteristic that is important to the microwave device engineer. The engineer uses the saturation magnetization as a design parameter that enters into the initial selection of a ferrimagnetic material for microwave device applications. Typical ferrimagnets exhibit values of $4\pi Ms$ between 300 Gauss (G) and 5000 G.

Static or low frequency methods are generally used to measure $4\pi Ms$.

Magnetometer Method

The test specimen is a sphere with a diameter of approximately 0.100 inches. When placed in a uniform strong Direct Current (DC) magnetic field, the sphere becomes uniformly magnetized in a direction parallel to the applied field. External to the sphere, the field resulting from this magnetization is exactly that of a magnetic dipole located at the center of the sphere oriented parallel to the magnetization. The strength of this dipole field is proportional to the magnetic moment of the sphere (i.e., to M_sV , where V is the volume of the sphere).

If R_1 is the reading for the dipole field's strength of one sphere of magnetization M_1 and volume V_1 , and R_2 is the reading for a second standard sphere (e.g., nickel) of magnetization M_2 and volume V_2 , then:

$$\frac{R_1}{R_2} = \frac{M_1 V_1}{M_2 V_2} = \frac{M_1 d_1^3}{M_2 d_2^3} \quad (1)$$

Where:

- R = Reading for the dipole field's strength.
- M = Magnetization.
- V = Volume.
- d = Diameters of the two spheres.

If M_2 is known, then Equation 1 permits experimental determination of M_1 .

Figure 1 shows a device for measuring the saturation magnetization of ferrimagnet spheres, which is called a vibrating sample magnetometer. By means of an electromechanical transducer (A) and tube (B), the sample is vibrated vertically between pickup coils (C) in a horizontal DC magnetic field. A suitable frequency of vibration may be 100 cps. As a result of the changing linkage of the dipole flux with the coils, a signal is induced in the coils at the vibration frequency.

The coil arrangement shown in Figure 1 is one of several satisfactory arrangements. In this case, the two coils are connected in series opposition with respect to stray fields, and the signal voltages in the two coils will then add. The size of this "specimen signal" is proportional to the magnetic moment of the ferrimagnet under test.

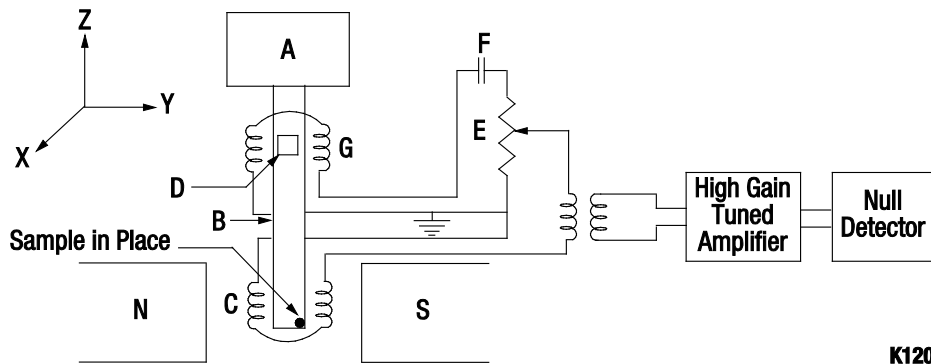

K120

Figure 1. Typical Vibrating Sample Magnetometer Setup Diagram

APPLICATION NOTE • TEST FOR SATURATION MAGNETIZATION

In Figure 1, a small DC permanent magnet (D) is mounted in the tube outside the DC magnetic field and situated between another set of pickup coils (G). This magnet is oriented so that its magnetic moment lies on the line connecting the centers of the two coils.

Figure 1 shows a suitable means for selecting an adjustable fraction of the reference signal from these coils so that the specimen signal is balanced by a measured fraction of the reference signal.

The fraction of the reference signal used is chosen by the precision potentiometer (E), and the reading of the potentiometer dial is proportional to the fraction. This signal is combined at 180 °C out of phase with the specimen signal by means of the transformer.

The capacitor (F) resonates the inductance of the reference coils, thereby avoiding an undesirable phase difference between the specimen and reference signals applied to the transformer. The strength of the dipole field is thus proportional to the reading R of the potentiometer dial when the fraction of the reference voltage is adjusted to obtain a null in the output of the amplifier. The amplifier is tuned to the vibration frequency.

Measurement

- Attach the specimen at the end of the rod, and then cause it to vibrate perpendicular to the DC magnetic field. To minimize dependence on the specimen position, center the specimen with respect to the coils by positioning for a minimum of specimen signal with respect to motion in the Y direction and for a maximum with respect to motion in the X and Z directions. Determine the reading R corresponding to the fraction of the reference signal required to balance out the specimen signal.
- The measurement of saturation magnetization requires that the specimen be saturated. For most microwave ferrites, a satisfactory criterion for saturation is that a decrease in the applied DC magnetic field by 25% shall result in no more than a 1% decrease in the R indication.
- The $4\pi M_s$ of the unknown ferrite specimen may then be calculated from Equation 1. A suitable material for the standard specimen is pure nickel. The saturation induction of pure nickel at room temperature is 6070 G. This value applies to a nonporous specimen of density 8.90 G/cm³.

Copyright © 2013, Trans-Tech Inc., Inc. All Rights Reserved.

Information in this document is provided in connection with Trans-Tech, Inc. ("Trans-Tech"), a wholly-owned subsidiary of Skyworks Solutions, Inc. These materials, including the information contained herein, are provided by Trans-Tech as a service to its customers and may be used for informational purposes only by the customer. Trans-Tech assumes no responsibility for errors or omissions in these materials or the information contained herein. Trans-Tech may change its documentation, products, services, specifications or product descriptions at any time, without notice. Trans-Tech makes no commitment to update the materials or information and shall have no responsibility whatsoever for conflicts, incompatibilities, or other difficulties arising from any future changes.

No license, whether express, implied, by estoppel or otherwise, is granted to any intellectual property rights by this document. Trans-Tech assumes no liability for any materials, products or information provided hereunder, including the sale, distribution, reproduction or use of Trans-Tech products, information or materials, except as may be provided in Trans-Tech Terms and Conditions of Sale.

THE MATERIALS, PRODUCTS, AND INFORMATION ARE PROVIDED "AS IS" WITHOUT WARRANTY OF ANY KIND, WHETHER EXPRESS, IMPLIED, STATUTORY, OR OTHERWISE, INCLUDING FITNESS FOR A PARTICULAR PURPOSE OR USE, MERCHANTABILITY, PERFORMANCE, QUALITY, OR NON-INFRINGEMENT OF ANY INTELLECTUAL PROPERTY RIGHT; ALL SUCH WARRANTIES ARE HEREBY EXPRESSLY DISCLAIMED. TRANS-TECH DOES NOT WARRANT THE ACCURACY OR COMPLETENESS OF THE INFORMATION, TEXT, GRAPHICS, OR OTHER ITEMS CONTAINED WITHIN THESE MATERIALS. TRANS-TECH SHALL NOT BE LIABLE FOR ANY DAMAGES, INCLUDING BUT NOT LIMITED TO ANY SPECIAL, INDIRECT, INCIDENTAL, STATUTORY, OR CONSEQUENTIAL DAMAGES, INCLUDING WITHOUT LIMITATION, LOST REVENUES OR LOST PROFITS THAT MAY RESULT FROM THE USE OF THE MATERIALS OR INFORMATION, WHETHER OR NOT THE RECIPIENT OF MATERIALS HAS BEEN ADVISED OF THE POSSIBILITY OF SUCH DAMAGE.

Trans-Tech products are not intended for use in medical, lifesaving, or life-sustaining applications, or other equipment in which the failure of the Trans-Tech products could lead to personal injury, death, or physical or environmental damage. Trans-Tech customers using or selling Trans-Tech products for use in such applications do so at their own risk and agree to fully indemnify Trans-Tech for any damages resulting from such improper use or sale.

Customers are responsible for their products and applications using Trans-Tech products, which may deviate from published specifications as a result of design defects, errors, or operation of products outside of published parameters or design specifications. Customers should include design and operating safeguards to minimize these and other risks. Trans-Tech assumes no liability for applications assistance, customer product design, or damage to any equipment resulting from the use of Trans-Tech products outside of stated published specifications or parameters.